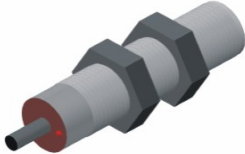
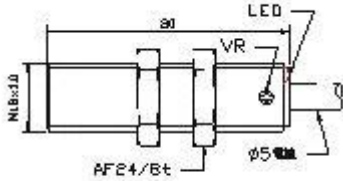
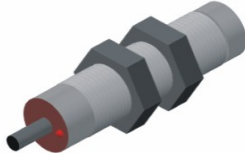
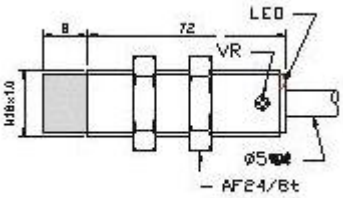

*TLK-M18 Capacitive Series*

- 👍 Can detect metal, non metal, glass, liquid, plastic, silicone chip, powder... etc... The detected distance varied along closely with the property of factors such as electric ion (electric conductive coefficient or non electric conductive coefficient), moisture content, the volume of the object. These will affect the detection distance accordingly.
- 👍 Very stable, totally not affected by disturbance from inverter.
- 👍 Attached with sensitivity adjuster which can set distance effectively.
- 👍 Available detection distances are 8 ~ 12mm with plenty models.
- 👍 Available with DC type & AC type.

Switching Output	Model Number	Operating voltage	Response frequency	Sensing distance
DC 3-Wire NPN NO	TLK-F18N08E1	DC 12~24V	30Hz	8mm
DC 3-Wire PNP NO	TLK-F18P08E1			
AC 2-Wire NO	TLK-F18A08E1	AC 20~250V	10Hz	

Switching Output	Model Number	Operating voltage	Response frequency	Sensing distance
DC 3-Wire NPN NO	TLK-N18N12E1	DC 12~24V	15Hz	12mm
DC 3-Wire PNP NO	TLK-N18P12E1			

Item	Specifications
Load current	0 ~ 200mA
Operation indicator	Yellow LED

Circuits protection	Short circuit protection
Enclosure protection	IEC IP67
Ambient temperature & humidity range	Operating : -25 ~ 70°C / RH 35 ~85% (with no icing or condensation)
Housing material	PBT
Connecting method	Pre-wired 2M Cable