

**XC-SP25M Series**

- 👍 Equipped with removable glass lens especially for severe environment.
- 👍 With built-in amplifier. Short tube type. (M18x1, 45mm length), meet CENELEC standard specifications
- 👍 Structure protection reaches IEC IP67. Water proof, oil resistance, shock resistance. .. excellent anti severe job environment performance.
- 👍 Excellent stability with perfect anti interference: anti invert frequency, anti electric noise (high frequency florescent light), anti electromagnetic wave, anti sunlight ... etc. ,
- 👍 Detection distance: 25M. offers output models: NPN NO&NC · PNP NO&NC two types.

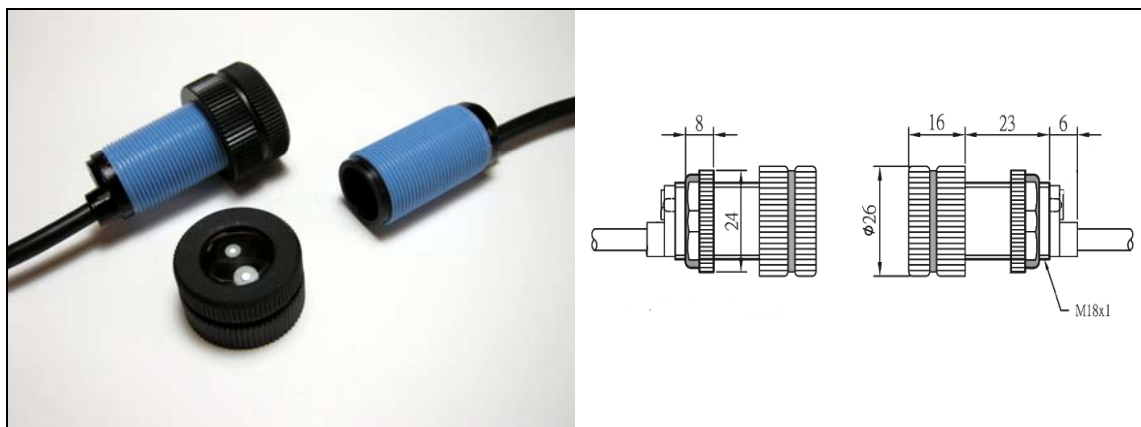

Model number	Switching output	Sensing distance	Sensing method	Operating voltage
XC-SP25MN	NPN	25M	Through-beam	DC 12~24V ripple ≤ 10%
XC-SP25MP	PNP			

Item	Specifications
Control output	NPN NO&NC · PNP NO&NC
esponse time	< 5ms
Load current	< 100mA
Light source	Infraed LED
Operation indicator	Red LED
Circuits protection	Reversed polarity & Short circuit protection
Enclosure protection	IEC IP67
Ambient temperature & humidity range	Operating : -20 ~ 55°C / RH 35 ~85% (with no icing or condensation)
Ambient illumination	Lamplight < 3000 Lux / Sunlight < 10000 Lux
Connecting method	Pre-wired 2M Cable
Housing material	Case : ABS / Lens : Glass
Accessories	Nuts