

XC-SP8GM Series

- 👍 Equipped with insert type connector, impact resistance, easy installation and maintenance
- 👍 With built-in amplifier. Short tube type. (M18X1, 30mm length), meet CENELEC standard specifications
- 👍 Structure protection reaches IEC IP67. Water proof, oil resistance, shock resistance. ... excellent anti severe job environment performance.
- 👍 Excellent stability with perfect anti interference: anti invert frequency, anti electric noise (high frequency florescent light), anti electromagnetic wave, anti sunlight ... etc.

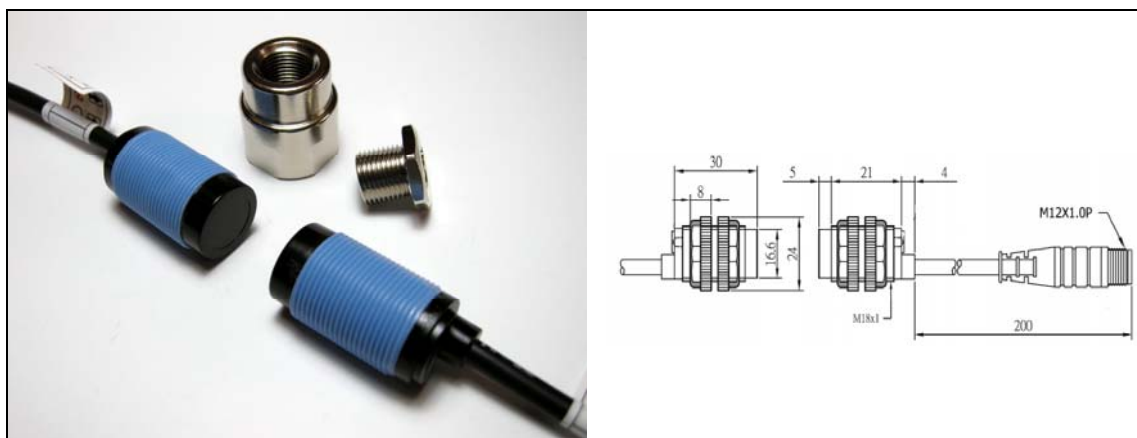

Model number	Switching output	Sensing method	Sensing distance	Connecting method
XC-SP8GMN	NPN	Through-beam	8M	Pre-wired 2M Cable
XC-SP8GMN-J				Cable with Quick connector
XC-SP8GMP	PNP			Pre-wired 2M Cable
XC-SP8GMP-J				Cable with Quick connector

Item	Specifications
Operating voltage	DC 12~24V · ripple ≤ 10%
Control output	NPN NO & NC · PNP NO & NC
Response time	< 5ms
Load current	< 100mA
Light source	Infraed LED
Operation indicator	Red LED
Circuits protection	Reversed polarity & Short circuit protection
Enclosure protection	IEC IP67
Ambient temperature & humidity range	Operating : -20 ~ 55°C / RH 35 ~85% (with no icing or condensation)
Ambient illumination	Lamplight < 3000 Lux / Sunlight < 10000 Lux
Housing material	Case : ABS / Lens : Acrylic
Accessories	Nuts